

Distraction Related Accidents: Eyes on Road, Hands on Wheel, AND Mind on Task

Sarah Wrenn, ThinkReliability

Admit it – you’ve checked your phone while driving. We’ve likely all been guilty of it at some point. And despite knowing that we’re not supposed to do it – it’s against the law in most states and we understand that the distraction increases our risk of having an accident – we still do it. Why?

On March 31, 2015, the National Transportation Safety Board (NTSB) held its first roundtable discussion on distractions within the transportation industry. In 2015, the NTSB added “Disconnect from Deadly Distractions” to its “Most Wanted List of Transportation Safety Improvements for 2015.” This list represents the NTSB’s priorities to increase awareness and support for key issues related to transportation safety. Other critical topics include “Make Mass Transit Safer” and “Require Medical Fitness for Duty.”

Representatives from all modes of transportation, technology, law enforcement, insurance, researchers, advocates, and educators came together for discussion related to distractions facing vehicle operators.

“New technologies are connecting us as never before – to information, to entertainment, and to each other,” said NTSB Member Robert Sumwalt. “But when those technologies compete for our attention while we’re behind the wheel of a car or at the controls of other vehicles, the results can be deadly.”

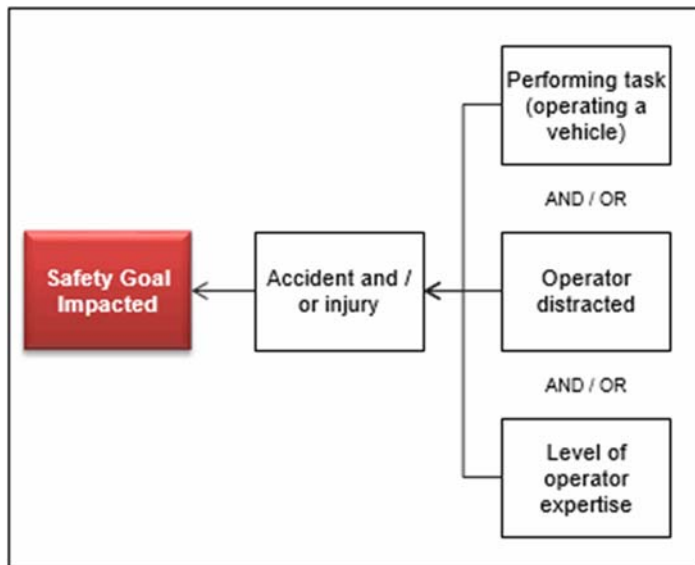

Digging into the causes

So let’s take a look at some of the causes related to an accident where the operator is distracted. In addition to the accident occurring because of the distraction, the level of driver expertise is also a factor. A large effort has been made to raise awareness and provide education to teenage drivers. This is in part because, as novice drivers, they have a more limited exposure to driving situations and may not have the ability to react as a more skilled driver.

Operators become distracted

We also want to understand the causes that led to the operator being distracted. There is a distraction type (or mode) that was introduced, the duration of the distraction, and the individual's inability to ignore the distraction that result in the operator distraction. While the type of distraction plays a large role in taking the operator's eyes off the road, hands off the wheel or mind off the task, the duration of the distraction also is a key factor. For example, while one's eyes remain on the road during a phone call, the duration of that call disengages the brain from the task for more time than the act of dialing the phone. This is not to say that one of these actions is more or less impactful; it is important to note that they both play a role in distracting the individual.

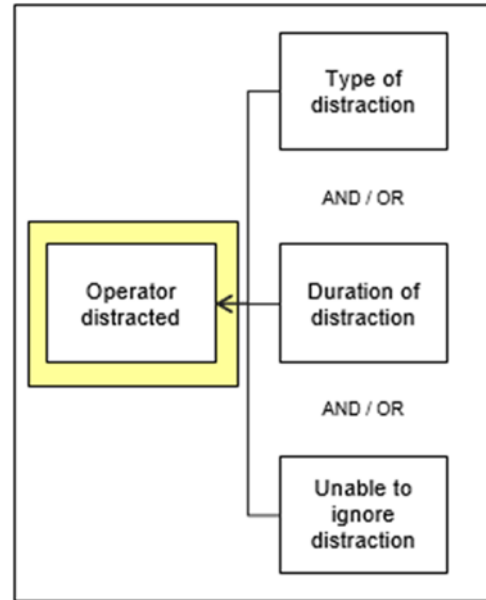

It's not just the text that is distracting

There are three primary forms of distractions – Visual (taking eyes off of the road), Manual (taking hands off of the wheel), and Cognitive (taking mind off of the task). Visual and manual types of distractions are very easy to define and generally recognized as risky behaviors while operating a vehicle. Cognitive distractions are less tangible and therefore more difficult to define. Research and studies generally define cognitive distractions as when the individual's attention is divided between two or more tasks.

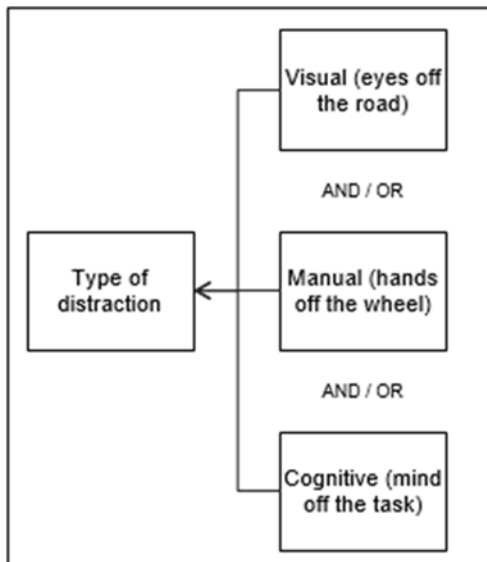

While technology and activities such as texting or talking on the phone are typically identified as the primary forms of distraction, it is interesting to note that cognitive distractions such as allowing your mind to wander while operating a vehicle can be just as risky. The AAA Foundation released a 2013 study "[Measuring Cognitive Distraction in the Automobile](#)." The study rates various tasks such as using a hands-free cell phone and listening to the radio according to the amount of cognitive workload imposed upon an operator. The study concludes that "while some tasks, like listening to the radio, are not very distracting, others – such as maintaining phone conversations and interacting with speech-to-text systems – place a high cognitive demand on drivers and degrade performance and brain activity necessary for safe driving."

The forum discussed the concept that ability to multi-task is actually a myth, with evidence and data to conclude that for certain types of activities multi-tasking is not only difficult, but impossible. For example, tasks such as navigation and speech require the use of the same circuits within the brain. As such, the brain cannot do both tasks at once. Instead, the brain is switching between these tasks, resulting in a reduction of focus on the primary task (driving) while attempting to perform a secondary task (speaking). Therefore, attempting to multi-task introduces a cognitive distraction that increases the risk of unsafe driving.

Just ignore it

Why don't we just ignore the temptation to become distracted?

Our brains function by releasing serotonin and dopamine when an action occurs that makes us feel good. Dr. Paul Atchley of the University of Kansas stated: "There is nothing more interesting to the human brain than other people. I don't care how you design your vehicle or your roadways, if you have technologies in the vehicle that allow you to be social, your brain will not be able to ignore them. There are only two things we love, serotonin and dopamine. The two reward chemicals that come along with all those other things that make us feel good. There is really nothing more rewarding to us than the opportunity to talk to someone else."

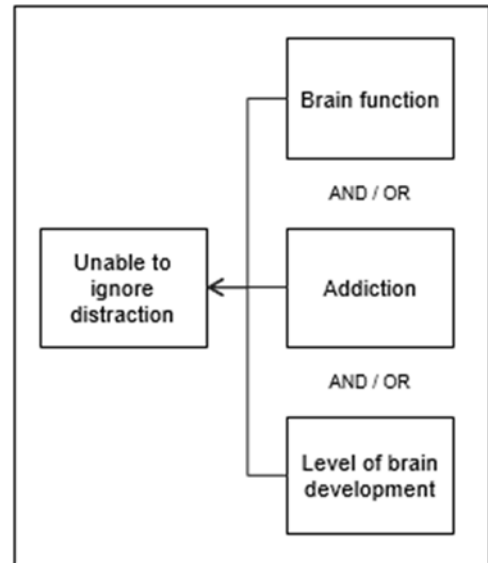

Surveys performed by various organizations have revealed a large percentage of people (sometimes 3 out of 4) that will admit to being distracted while driving. Meanwhile, a staggering percent (upwards of 90%) will rationalize the behavior which is a sign of addiction.

Finally, the level of brain development controls our ability to respond to distractions. For example, a teenager has a less developed frontal cortex than an adult which means, as Dr. David Strayer of the University of Utah explains: "Teens' frontal cortex, the parts of the brain that do decision-making in terms of multitasking, are underdeveloped." Much of the focus on distracted driving is focused on teens and this is justified as their brain development is not yet complete. It is, however, important to note that this is not just an issue for teens who can't be separated from their phones or seniors who don't understand them; this is an issue that crosses all demographics. Level of brain development is just one factor.

So what can we do?

At the end of the day, we want to identify solutions that are going to effectively reduce the risk of having accidents related to distractions from occurring. While there will always be some risk, it is key to take a comprehensive approach to education, technology, and policy. Programs like EndDD.org and stopdistractions.org are focused on bringing awareness, education, and training to youth and adults about the risks of operating vehicles while distracted. Technology can also be used in a variety of ways to reduce the risk of these types of accidents. Sensors can be built into vehicles to identify distractions and provide alerts to drivers or apps can be used to disable functions of technology so the receipt of calls and texts are delayed. Finally, establishing policies and laws that are realistic and enforceable is important so that individuals are held accountable for risky behaviors before an accident occurs. No one single solution is going to reach everyone and no one single solution is going to eliminate the risk of deadly accidents. Each one of these solutions has limitations, but they also have advantages. With a balanced approach to raise awareness and education, provide resources and tools to drivers, and change the culture of what is acceptable while driving, we can reduce the amount of accidents and save lives.

References:

NTSB Roundtable: Disconnect from Deadly Distractions held March 31, 2015, from 9:00 a.m. – 4:00 p.m.,
http://www.nts.gov/news/events/Pages/2015_Distraction_forum.aspx

AAA Foundation: Measuring Cognitive Distraction in the Automobile, June 2013;
https://www.aaafoundation.org/sites/default/files/MeasuringCognitiveDistractionFS_1.pdf

DISTRACTION RELATED ACCIDENTS

Eyes on Road, Hands on Wheel, AND Mind on Task

On March 31, 2015, the National Transportation Safety Board (NTSB) held its first roundtable discussion on distractions within the transportation industry. Representatives from all modes of transportation, technology, law enforcement, insurance, researchers, advocates, and educators came together for discussion related to operator distractions.

"New technologies are connecting us as never before – to information, to entertainment, and to each other," said NTSB Member Robert Sumwalt. "But when those technologies compete for our attention while we're behind the wheel of a car or at the controls of other vehicles, the results can be deadly."

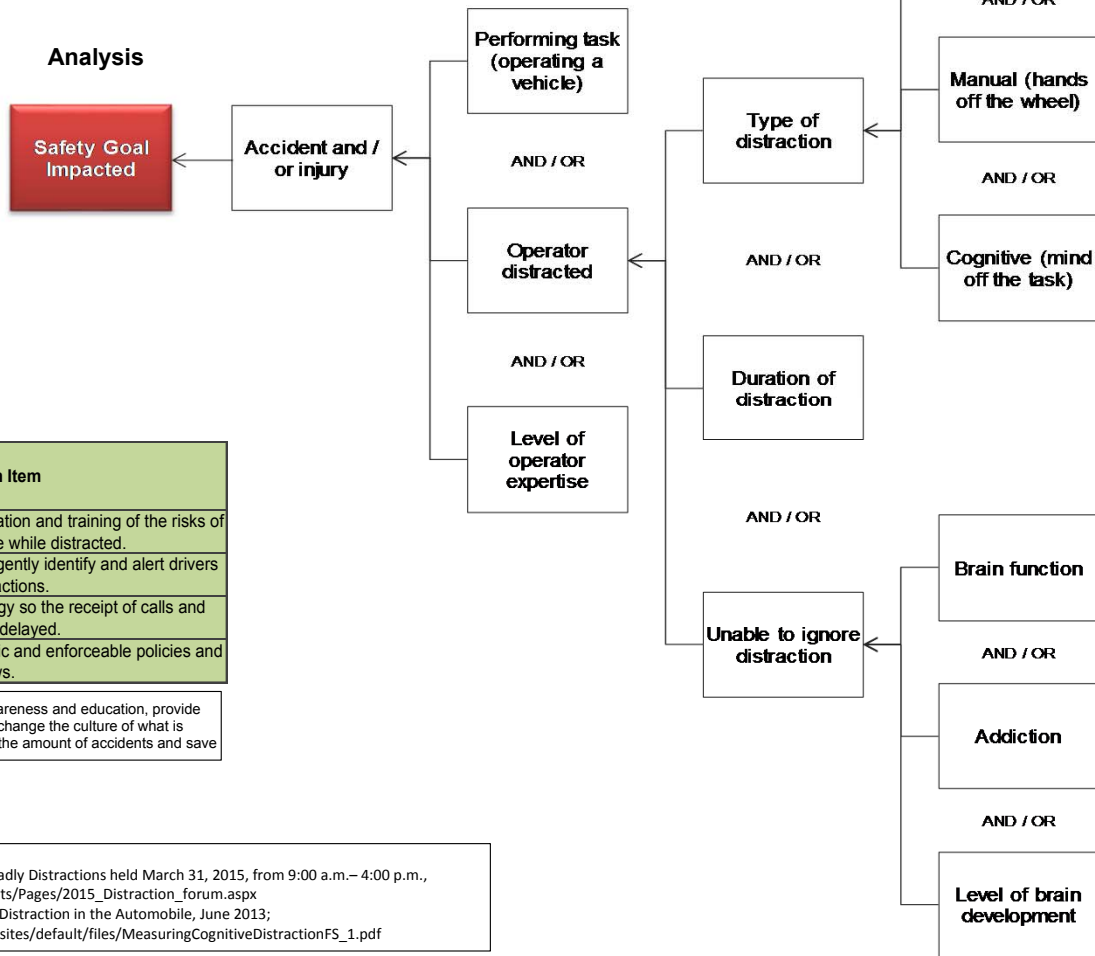

Solutions

No.	Action Item
1	Raise awareness through education and training of the risks of operating a vehicle while distracted.
2	Implement technology to intelligently identify and alert drivers of distractions.
3	Disable functions of technology so the receipt of calls and texts are delayed.
4	Establish and implement realistic and enforceable policies and laws.

With a balanced approach to raise awareness and education, provide resources and tools to drivers, and change the culture of what is acceptable while driving, we can reduce the amount of accidents and save

References:

NTSB Roundtable: Disconnect from Deadly Distractions held March 31, 2015, from 9:00 a.m.– 4:00 p.m., http://www.nts.gov/news/events/Pages/2015_Distracton_forum.aspx
 AAA Foundation: Measuring Cognitive Distraction in the Automobile, June 2013; https://www.aaafoundation.org/sites/default/files/MeasuringCognitiveDistractionFS_1.pdf

Cause Mapping is a Root Cause Analysis method that captures basic cause-and-effect relationships supported with evidence.

CAUSE MAPPING

Problem Solving • Incident Investigation • Root Cause Analysis

- Step 1 **Problem** What's the Problem?
- Step 2 **Analysis** Why did it happen?
- Step 3 **Solutions** What will be done?

Why?

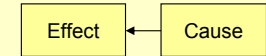

NOTE: Read the Cause Map from left to right with the phrase "Was Caused By" in place of each arrow.

For a free copy of our Root Cause Analysis Template in Microsoft Excel, used to create this page, visit our web site.

ThinkReliability

Investigate Problems. Prevent Problems.
 Houston, Texas 281-412-7766 ThinkReliability.com

Copyright ThinkReliability 2015